



BIROn - Birkbeck Institutional Research Online

Pokrovskiy, Alexey (2014) Partitioning edge-coloured complete graphs into monochromatic cycles and paths. *Journal of Combinatorial Theory, Series B* 106 , pp. 70-97. ISSN 0095-8956.

Downloaded from: <https://eprints.bbk.ac.uk/id/eprint/24978/>

Usage Guidelines:

Please refer to usage guidelines at <https://eprints.bbk.ac.uk/policies.html> or alternatively contact lib-eprints@bbk.ac.uk.

Partitioning edge-coloured complete graphs into monochromatic cycles and paths

Alexey Pokrovskiy *

Departement of Mathematics,
London School of Economics and Political Sciences,
London WC2A 2AE, UK
Email: a.pokrovskiy@lse.ac.uk

May 25, 2012

Abstract

A conjecture of Erdős, Gyárfás, and Pyber says that in any edge-colouring of a complete graph with r colours, it is possible to cover all the vertices with r vertex-disjoint monochromatic cycles. So far, this conjecture has been proven only for $r = 2$. In this paper we show that in fact this conjecture is false for all $r \geq 3$. In contrast to this, we show that in any edge-colouring of a complete graph with three colours, it is possible to cover all the vertices with three vertex-disjoint monochromatic *paths*, proving a particular case of a conjecture due to Gyárfás. As an intermediate result we show that in any edge-colouring of the complete graph with the colours red and blue, it is possible to cover all the vertices with a red path, and a disjoint blue balanced complete bipartite graph.

1 Introduction

Suppose that the edges of the complete graph on n vertices, K_n , are coloured with r colours. How many vertex-disjoint monochromatic paths are needed to cover all the vertices of K_n ? Gerencsér and Gyárfás [7] showed that when $r = 2$, this can always be done with at most two monochromatic paths. For $r > 2$, Gyárfás made the following conjecture.

Conjecture 1.1 (Gyárfás, [9]). *The vertices of every r -edge coloured complete graph can be covered with r vertex-disjoint monochromatic paths.*

*Research supported by the LSE postgraduate research studentship scheme.

Subsequently, Erdős, Gyárfás, and Pyber made the following stronger conjecture.

Conjecture 1.2 (Erdős, Gyárfás & Pyber, [6]). *The vertices of every r -edge coloured complete graph can be covered with r vertex-disjoint monochromatic cycles.*

When dealing with these conjectures, the empty set, a single vertex, and a single edge between two vertices are considered to be paths and cycles. It is worth noting that neither of the above conjectures require the monochromatic paths covering K_n to have distinct colours. Whenever a graph G is covered by vertex-disjoint subgraphs H_1, H_2, \dots, H_k , we say that H_1, H_2, \dots, H_k partition G .

Most effort has focused on Conjecture 1.2. It was shown in [6] that there is a function $f(r)$ such that, for all n , any r -edge coloured K_n can be partitioned into $f(r)$ monochromatic cycles. The best known upper bound for $f(r)$ is due to Gyárfás, Ruszinkó, Sárközy, and Szemerédi [11] who show that, for large n , $100r \log r$ monochromatic cycles are sufficient to partition the vertices of an r -edge coloured K_n .

For small r , there has been more progress. The case $r = 2$ of Conjecture 1.2 is closely related to Lehel's Conjecture, which says that any 2-edge coloured complete graph can be partitioned into two monochromatic cycles *with different colours*. This conjecture first appeared in [2] where it was proved for some special types of colourings of K_n . Gyárfás [8] showed that the vertices of a 2-edge coloured complete graph can be covered by two monochromatic cycles with different colours intersecting in at most one vertex. Łuczak, Rödl, and Szemerédi [14] showed, using the Regularity Lemma, that Lehel's Conjecture holds for $r = 2$ for large n . Later, Allen [1] gave an alternative proof that works for smaller (but still large) n , and which avoids the use of the Regularity Lemma. Lehel's Conjecture was finally shown to be true for all n by Bessy and Thomassé [4], using a short, elegant argument.

For $r = 3$, Gyárfás, Ruszinkó, Sárközy, and Szemerédi proved the following theorem.

Theorem 1.3 (Gyárfás, Ruszinkó, Sárközy & Szemerédi, [12]). *Suppose that the edges of K_n are coloured with three colours. There are three vertex-disjoint monochromatic cycles covering all but $o(n)$ vertices in K_n .*

In [12], it is also shown that, for large n , 17 monochromatic cycles are sufficient to partition *all* the vertices of every 3-edge coloured K_n .

Despite Theorem 1.3 being an approximate version of the case $r = 3$ of Conjecture 1.2, the conjecture turns out to be false for all $r \geq 3$. We prove the following theorem in Section 2.

Theorem 1.4. *Suppose that $r \geq 3$. There exist infinitely many r -edge coloured complete graphs which cannot be vertex-partitioned into r monochromatic cycles.*

For a particular counterexample of low order to the case $r = 3$ of Conjecture 1.2, see Figure 1. It is worth noting that in all the r -colourings of K_n that we construct, it is possible to cover $n - 1$ of the vertices of K_n with r disjoint monochromatic cycles. Therefore the counterexamples we construct are quite “mild” and leave room for further work to either

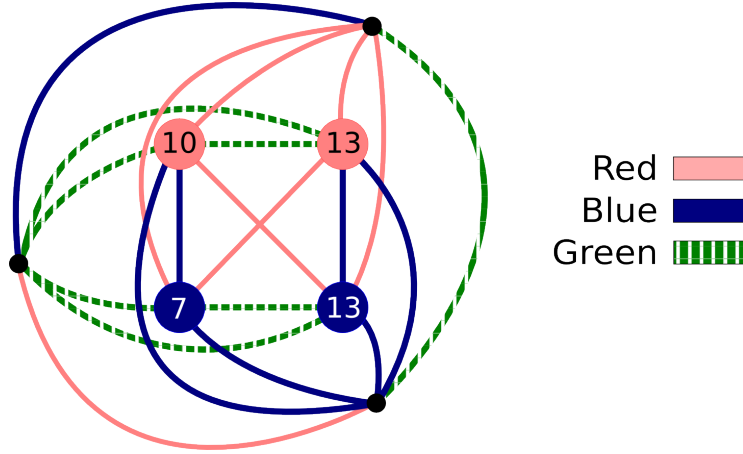

Figure 1: A 3-edge colouring of K_{46} which cannot be partitioned into three monochromatic cycles. The small black dots represent single vertices. The large red and blue circles represent red and blue complete graphs of order specified by the numbers inside. The coloured lines between the sets represent all the edges between them being of that colour. This particular colouring is called J_3^1 in this paper. In Section 2 we prove that this colouring does not allow a partition into three monochromatic cycles.

find better counterexamples, or to prove approximate versions of the conjecture similar to Theorem 1.3.

Theorem 1.4 also raises the question of whether Conjecture 1.1 holds for $r \geq 3$ or not. The second main result of this paper is to prove the case $r = 3$ of Conjecture 1.1.

Theorem 1.5. *For $n \geq 1$, suppose that the edges of K_n are coloured with three colours. There is a vertex-partition of K_n into three monochromatic paths.*

Theorem 1.5 is proved in Section 3.

One way of generalizing the conjectures and theorems above is to consider partitions of an r -edge coloured graph G other than the complete graph. Some results in this direction were already obtained in [15] where G is an arbitrary graph with specified independence number, and in [3] where G is an arbitrary graph with $\delta(G) \geq \frac{3}{4}$. In order to prove Theorem 1.5 we will consider partitions of a 2-edge coloured balanced complete bipartite graph (the complete bipartite graph $K_{n,m}$ is called *balanced* if $n = m$ holds). In order to state our result we will need the following definition.

Definition 1.6. *Let $K_{n,n}$ be a 2-edge coloured balanced complete bipartite graph with partition classes X and Y . We say that the colouring on $K_{n,n}$ is **split** if it is possible to partition X into two nonempty sets X_1 and X_2 , and Y into two nonempty sets Y_1 and Y_2 , such that the following hold.*

- *The edges between X_1 and Y_2 , and the edges between X_2 and Y_1 are red.*
- *The edges between X_1 and Y_1 , and the edges between X_2 and Y_2 are blue.*

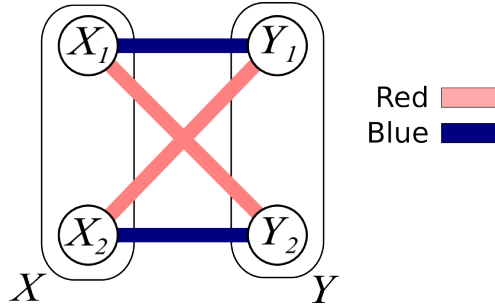

Figure 2: A split colouring of $K_{n,n}$.

The sets X_1 , X_2 , Y_1 , and Y_2 will be called the “classes” of the split colouring.

When dealing with split colourings of $K_{n,n}$ the classes will always be labeled “ X_1 ”, “ X_2 ”, “ Y_1 ”, and “ Y_2 ” with colours between the classes as in the above definition. See Figure 2 for an illustration of a split colouring of K_n .

These colourings have previously appeared in the following theorem due to Gyarfas and Lehel. The proof of this theorem appears implicitly in [10], and the statement appears in [8].

Theorem 1.7 (Gyarfas & Lehel, [8, 10]). *Suppose that the edges of $K_{n,n}$ are coloured with two colours. If the colouring is not split, then there exist two disjoint monochromatic paths with different colours which cover all, except possibly one, of the vertices of $K_{n,n}$.*

We will prove the following slight extension of Theorem 1.7.

Theorem 1.8. *Suppose that the edges of $K_{n,n}$ are coloured with two colours. There is a vertex-partition of $K_{n,n}$ into two monochromatic paths with different colours if, and only if, the colouring on $K_{n,n}$ is not split.*

There exist split colourings of $K_{n,n}$ which cannot be partitioned into two monochromatic paths even when we are allowed to repeat colours. Indeed, any split colouring with classes X_1 , X_2 , Y_1 , and Y_2 , satisfying $||X_1| - |Y_1|| \geq 2$ and $||X_1| - |Y_2|| \geq 2$ will have this property. Using Theorem 1.8, it is not hard to show that any 2-colouring of $K_{n,n}$ which cannot be partitioned into two monochromatic paths must be a split colouring with class sizes as above.

However, it is easy to check that every 2-edge coloured $K_{n,n}$ which is split can be partitioned into three monochromatic paths, so the following corollary follows from either of the above two theorems.

Corollary 1.9. *Suppose that the edges of $K_{n,n}$ are coloured with two colours. There is a vertex-partition of $K_{n,n}$ into three monochromatic paths.*

Recall that Gerencser and Gyarfas showed that any 2-edge coloured complete graph K_n can be partitioned into two monochromatic paths. The following lemma, which may be of independent interest, shows that one of the paths partitioning K_n can be replaced by a graph which has more structure.

Lemma 1.10. *Suppose that the edges of K_n are coloured with the colours red and blue. There is a vertex-partition of K_n into a red path and a blue balanced complete bipartite graph.*

Lemma 1.10 and Corollary 1.9 together easily imply that a 3-edge coloured complete graph can be partitioned into *four* monochromatic paths. Indeed suppose that K_n is coloured with the colours red, blue and green. First we treat blue and green as a single colour and apply Lemma 1.10 to obtain a partition of K_n into a red path and a blue-green balanced complete bipartite graph. Now apply Corollary 1.9 to this graph to obtain a partition of K_n into four monochromatic paths.

The proof of Theorem 1.5 is more involved, and we will need a more refined version of Lemma 1.10 which is stated and proved in Section 3.1.

2 Counterexamples to the conjecture of Erdős, Gyárfás, and Pyber.

In this section, for $r \geq 3$, we will prove Theorem 1.4, by constructing a sequence of r -edge coloured complete graphs, J_r^m , which cannot be partitioned into r monochromatic cycles. First we will construct a sequence of r -edge coloured complete graphs, H_r^m , which cannot be partitioned into r monochromatic paths *with different colours*.

Construction 2.1. *Let r and m be integers such that $r \geq 3$ and $m \geq 1$. We construct r -edge coloured complete graphs, H_r^m , on $(\frac{87}{250}5^r - \frac{1}{2})m$ vertices. First, we will consider the $r = 3$ and $m \geq 1$ cases and define the colourings H_3^m . Then for $r \geq 4$ we will then construct the graphs H_r^m recursively out of H_{r-1}^{5m} .*

- *Suppose that $r = 3$. To construct H_3^m , we 3-edge colour K_{43m} as follows. We partition the vertex set of K_{43m} into four classes A_1, A_2, A_3 , and A_4 such that $|A_1| = 10m$, $|A_2| = 13m$, $|A_3| = 7m$, and $|A_4| = 13m$. The edges between A_1 and A_2 and between A_3 and A_4 are colour 1. The edges between A_1 and A_3 and between A_2 and A_4 are colour 2. The edges between A_1 and A_4 and between A_2 and A_3 are colour 3. The edges within A_1 and A_2 are colour 3. The edges within A_3 and A_4 are colour 2.*
- *Suppose that $r \geq 4$. Note that the $|H_r^m| = |H_{r-1}^{5m}| + 2m$ holds, so we can partition the vertices of H_r^m into two sets H and K such that $|H| = |H_{r-1}^{5m}|$ and $|K| = 2m$. We colour H with colours $1, \dots, r-1$ to produce a copy of H_{r-1}^{5m} . All other edges are coloured with colour r .*

Construction 2.2. *Let r and m be integers such that $r \geq 3$ and $m \geq 1$. We construct r -edge coloured complete graphs, J_r^m , on $(\frac{87}{250}5^r - \frac{1}{2})m + r$ vertices.*

We partition the vertices of $|J_r^m|$ into a set H of order $|H_r^m|$ and a set of r vertices $\{v_1, \dots, v_r\}$. The edges in H are coloured to produce a copy of H_r^m . For each $i \in \{1, \dots, r\}$, we colour all the edges between v_i and H with colour i . The edge v_1v_2 is colour 3. For

$j \geq 3$ the edge v_1v_j is colour 2 and the edge v_2v_j is colour 1. For $3 \leq i < j$, the edge v_iv_j is colour 1.

The following simple fact will be convenient to state.

Lemma 2.3. *Let G be a graph, X an independent set in G , and P a path in G . Then we have*

$$|P \cap X| \leq |P \cap (G \setminus X)| + 1.$$

Proof. Let $x_1 \dots x_k$ be the vertex sequence of P . For $i \leq k - 1$, if x_i is in X , then x_{i+1} must be in $G \setminus X$, implying the result. \square

The only property of the graphs H_r^m that we will need is that they satisfy the following lemma.

Lemma 2.4. *Let $r \geq 3$ and $m \geq 1$ be integers. The following both hold.*

- (i) H_r^m cannot be vertex-partitioned into $r - 1$ monochromatic paths.
- (ii) H_r^m cannot be vertex-partitioned into r monochromatic paths with different colours.

Proof. It will be convenient to prove a slight strengthening of the lemma. Let T be any set of at most m vertices of H_r^m . We will prove that the graph $H_r^m \setminus T$ satisfies parts (i) and (ii) of the lemma.

The proof is by induction on r . First we shall prove the lemma for the initial case, $r = 3$.

Recall that H_3^m is partitioned into four sets A_1, A_2, A_3 , and A_4 . Let $B_i = A_i \setminus T$. Since $|T| \leq m$, the sets B_1, B_2, B_3 , and B_4 are all nonempty. We will need the following claim.

Claim 2.5. *The following hold.*

- (a) B_2 cannot be covered by a colour 1 path.
- (b) B_1 cannot be covered by a colour 2 path.
- (c) B_4 cannot be covered by a colour 3 path.
- (d) B_4 cannot be covered by a colour 1 path.
- (e) $B_1 \cup B_3$ cannot be covered by a colour 1 path contained in $B_1 \cup B_2$ and a disjoint colour 3 path contained in $B_2 \cup B_3$.
- (f) $B_2 \cup B_3$ cannot be covered by a colour 1 path contained in $B_3 \cup B_4$ and a disjoint colour 2 path contained in $B_2 \cup B_4$.

Proof.

- (a) Let P be any colour 1 path in $H_3^m \setminus T$ which intersects B_2 . The path P must then be contained in the colour 1 component $B_1 \cup B_2$. The set B_2 does not contain any colour 1 edges, so Lemma 2.3 implies that $|P \cap B_2| \leq |P \cap B_1| + 1$ holds. This, combined with the fact that $|T| \leq m$ holds, implies that we have

$$|P \cap B_2| \leq |P \cap B_1| + 1 \leq |A_1| + 1 = 10m + 1 < 12m \leq |B_2|.$$

This implies that P cannot cover all of B_2 .

- (b) This part is proved similarly to (a), using the fact that B_1 does not contain any colour 2 edges and that we have $|A_3| + 1 = 7m + 1 < 9m \leq |B_1|$.
- (c) This part is proved similarly to (a), using the fact that B_4 does not contain any colour 3 edges and that we have $|A_1| + 1 = 10m + 1 < 12m \leq |B_4|$.
- (d) This part is proved similarly to (a), using the fact that B_4 does not contain any colour 1 edges and that we have $|A_3| + 1 = 7m + 1 < 12m \leq |B_4|$.
- (e) Let P be a colour 1 path contained in $B_1 \cup B_2$ and let Q be a disjoint colour 3 path contained in $B_2 \cup B_3$. The set B_1 does not contain any colour 1 edges and B_3 does not contain any colour 3 edges, so Lemma 2.3 implies that $|(P \cup Q) \cap (B_1 \cup B_3)| \leq |(P \cup Q) \cap B_2| + 2$ holds. This, combined with the fact that $|T| \leq m$ holds, implies that we have

$$|(P \cup Q) \cap (B_1 \cup B_3)| \leq |(P \cup Q) \cap B_2| + 2 \leq |A_2| + 2 = 13m + 2 < 16m \leq |B_1 \cup B_3|$$

This implies that P and Q cannot cover all of $B_1 \cup B_3$.

- (f) This part is proved similarly to (e), using the fact that B_2 does not contain any colour 2 edges, B_3 does not contain any colour 1 edges, and that we have $|A_4| + 2 = 13m + 2 < 19m \leq |B_2 \cup B_3|$.

□

We now prove the lemma for $r = 3$. We deal with parts (i) and (ii) separately

- (i) Suppose, for the sake of contradiction, that P and Q are two monochromatic paths which partition $H_3^m \setminus T$. Note that P and Q cannot have different colours since any two monochromatic paths with different colours in H_3^m can intersect at most three of the four sets B_1, B_2, B_3 , and B_4 . The colouring $H_3^m \setminus T$ has exactly two components of each colour, so, for each i , the set B_i must be covered by either P or Q . This contradicts case (a), (b), or (c) of Claim 2.5 depending on whether P and Q have colour 1, 2, or 3.
- (ii) Suppose, for the sake of contradiction, that P_1, P_2 , and P_3 are three monochromatic paths which partition $H_3^m \setminus T$ such that P_i has colour i .

Suppose that $P_2 \subseteq B_1 \cup B_3$. By parts (c) and (d) of Claim 2.5, both of the paths P_1 and P_3 must intersect B_4 . This leads to a contradiction since none of the paths P_1 , P_2 , and P_3 intersect B_2 .

Suppose that $P_2 \subseteq B_2 \cup B_4$. If $P_1 \subseteq B_1 \cup B_2$ then P_3 must be contained in $B_2 \cup B_3$, contradicting part (e) of Claim 2.5. If $P_1 \subseteq B_3 \cup B_4$ then P_3 must be contained in $B_1 \cup B_4$, contradicting part (f) of Claim 2.5. This completes the proof of the lemma for the case $r = 3$.

We now prove the lemma for $r \geq 3$ by induction on r . The initial case $r = 3$ was proved above. Assume that the lemma holds for H_{r-1}^m , for all $m \geq 1$. Let H and K partition H_r^m as in the definition of H_r^m . Suppose that $H_r^m \setminus T$ is partitioned into r monochromatic paths P_1, \dots, P_r (with possibly some of these empty). Without loss of generality we may assume that these are ordered such that each of the paths P_1, \dots, P_k intersects K , and that each of the paths P_{k+1}, \dots, P_r is disjoint from K . Note that we have $k \leq |K| = 2m$. Let $S = H \cap (P_1 \cup \dots \cup P_k)$. The set $H \setminus T$ does not contain any colour r edges, so Lemma 2.3 implies that we have $|S| \leq |K| + k \leq 4m$, and so $|S \cup T| \leq 5m$. We know that $H \setminus (S \cup T)$ is partitioned into $r - k$ monochromatic paths P_{k+1}, \dots, P_r , so, by induction, we know that $k = 1$ and that the paths P_2, \dots, P_r are all nonempty and do not all have different colours. This completes the proof since we know that P_1 contains vertices in K , and hence P_1, \dots, P_r are all nonempty, and do not all have different colours. □

We now prove the main result of this section.

Theorem 2.6. *For $r \geq 3$ and $m \geq 1$, J_r^m cannot be vertex-partitioned into r monochromatic cycles.*

Proof. Let H and $\{v_1, \dots, v_r\}$ partition J_r^m as in the definition of J_r^m . Suppose that C_1, \dots, C_r are r disjoint monochromatic cycles in J_r^m . We need to show that $C_1 \cup \dots \cup C_r \neq J_r^m$. Note that, for any $i \neq j$, the edge $v_i v_j$ has a different colour to the edges between v_i and H . This means that monochromatic cycle in J_r^m cannot simultaneously pass through edges in $\{v_1, \dots, v_r\}$ and vertices in H .

Let $P_i = C_i \setminus \{v_1, \dots, v_r\}$. We claim that, for each i , P_i is a monochromatic path in H . If $C_i \cap \{v_1, \dots, v_r\} \leq 1$, then this is clear. So, suppose that for $j \neq k$ we have $v_j, v_k \in C_i$. In this case C_i cannot contain vertices in H , since otherwise the edges of C_i which pass through v_j and v_k would have different colours, contradicting the fact that C_i is monochromatic. This means that $P_i = \emptyset$, which is trivially a path.

Therefore P_1, \dots, P_r partition H into r monochromatic paths. By Lemma 2.4, they are all nonempty and not all of different colours. This means that there is a colour, say colour i , which is not present in any of the cycles C_1, \dots, C_r . For each j , the fact that P_j is nonempty implies that C_j does not contain edges in $\{v_1, \dots, v_r\}$. But then, the vertex v_i cannot be contained in any of the cycles C_1, \dots, C_r since all the edges between v_i and H have colour i . □

3 Partitioning a 3-coloured complete graph into three monochromatic paths.

In this section we prove Theorem 1.5.

Throughout this section, when dealing with $K_{n,n}$, the classes of the bipartition will always be called X and Y . For two sets of vertices S and T in a graph G , let $B(S, T)$ be the subgraph of G with vertex set $S \cup T$ with st an edge of $B(S, T)$ whenever $s \in S$ and $t \in T$. A *linear forest* is a disjoint union of paths.

For a nonempty path P , it will be convenient to distinguish between the two endpoints of P saying that one endpoint is the “start” of P and the other is the “end” of P . Thus we will often say things like “Let P be a path from u to v ”. Let P be a path from a to b in G and Q a path from c to d in G . If P and Q are disjoint and bc is an edge in G , then we define $P + Q$ to be the unique path from a to d formed by joining P and Q with the edge bc . If P is a path and Q is a subpath of P sharing an endpoint with P , then $P - Q$ will denote the subpath of P with vertex set $V(P) \setminus V(Q)$.

We will often identify a graph G with its vertex set $V(G)$. Whenever we say that two subgraphs of a graph are “disjoint” we will always mean vertex-disjoint. If H and K are subgraphs of G then $H \setminus K$ will mean $V(H) \setminus V(K)$ and $H \cup K$ will mean $V(H) \cup V(K)$. Additive notation will be reserved solely for concatenating paths as explained above.

All colourings in this section will be edge-colourings. Whenever a graph is coloured with two colours, the colours will be called “red” and “blue”. If there are three colours, they will be “red”, “blue”, and “green”. If a graph G is coloured with some number of colours we define the *red colour class* of G to be the subgraph of G with vertex set $V(G)$ and edge set consisting of all the red edges of G . We say that G is *connected in red*, if the red colour class is a connected graph. Similar definitions are made for blue and green as well.

We will need the following special 3-colourings of the complete graph.

Definition 3.1. *Suppose that the edges of K_n are coloured with three colours. We say that the colouring is **4-partite** if there exists a partition of the vertex set into four nonempty sets A_1, A_2, A_3 , and A_4 such that the following hold.*

- *The edges between A_1 and A_4 , and the edges between A_2 and A_3 are red.*
- *The edges between A_2 and A_4 , and the edges between A_1 and A_3 are blue.*
- *The edges between A_3 and A_4 , and the edges between A_1 and A_2 are green.*

The edges within the sets A_1, A_2, A_3 , and A_4 can be coloured arbitrarily. The sets A_1, A_2, A_3 , and A_4 will be called the “classes” of the 4-partition.

When dealing with 4-partite colourings of K_n , the classes will always be labeled “ A_1 ”, “ A_2 ”, “ A_3 ”, and “ A_4 ”, with colours between the classes as in the above definition. See Figure 3 for an illustration of a 4-partite colouring of K_n .

For all other notation, we refer to [5].

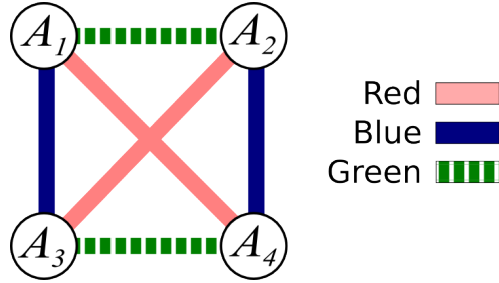

Figure 3: A 4-partite colouring of K_n .

In Section 2, we saw that there exist 3-colourings of the complete graphs which cannot be partitioned into three monochromatic paths *with different colours*. It turns out that all such colourings must be 4-partite. Our proof of Theorem 1.5 will split into the following two parts.

Theorem 3.2. *Suppose that the edges of K_n are coloured with three colours such that the colouring is not 4-partite. Then K_n can be vertex-partitioned into three monochromatic paths with different colours.*

Theorem 3.3. *Suppose that the edges of K_n are coloured with three colours such that the colouring is 4-partite. Then K_n can be vertex-partitioned into three monochromatic paths, at most two of which have the same colour.*

We will use Theorem 3.2 in the proof of Theorem 3.3.

3.1 Proof of Theorem 3.2.

We begin by proving the following strengthening of Lemma 1.10

Lemma 3.4. *Let G be a graph, and v a vertex in the largest connected component of G . There is a vertex-partition of G into a path P , and two sets A and B , such that there are no edges between A and B , and $|A| = |B|$. In addition P is either empty or starts at v .*

Proof. Let C be the largest connected component of G . We claim that there is a partition of G into a path P and two sets A and B such that the following hold:

- (i) $|A| \leq |B|$.
- (ii) There are no edges between A and B .
- (iii) P is either empty or starts from v .
- (iv) $|A \setminus C|$ is as large as possible (whilst keeping (i) - (iii) true).
- (v) $|A|$ is as large as possible (whilst keeping (i) - (iv) true).
- (vi) $|P|$ is as large as possible (whilst keeping (i) - (v) true).

To see that such a partition exists, note that letting $P = A = \emptyset$ and $B = V(G)$ gives a partition satisfying (i) - (iii), so there must be a partition having $|A \setminus C|$, $|A|$, and $|P|$ maximum, as required by (iv) - (vi).

Assume that P , A and B satisfy (i) - (vi). We claim that $|A| = |B|$ holds. Suppose, for the sake of contradiction, that we have $|A| < |B|$.

Suppose that P is empty. There are two cases depending on whether $C \subseteq A$ or $C \subseteq B$ holds. Note that, by (ii), we are always in one of these cases.

- Suppose that $C \subseteq A$. By (i) and (ii), there must be some connected component of G , say D , which is contained in B . In this case, let $P' = P$, $A' = (A \setminus C) \cup D$, and $B' = (B \setminus D) \cup C$. Using $|D| \leq |C|$ we obtain that $|A'| \leq |B'|$ holds. Therefore P' , A' , and B' partition G , satisfy (i) - (iii), and have $|A' \setminus C| = |A| - |C| + |D| > |A| - |C| = |A \setminus C|$. This contradicts $|A \setminus C|$ being maximal in the original partition.
- Suppose that $C \subseteq B$. In this case we have $v \in B$. Letting $P' = \{v\}$, $A' = A$, and $B' = B \setminus \{v\}$ gives a partition satisfying (i) - (v), and having $|P'| > |P|$. This contradicts P being maximal in the original partition.

Suppose that P is not empty. Let u be the end vertex of P . There are two cases depending on whether there are any edges between u and B

- Suppose that for some $w \in B$, uw is an edge. Letting $P' = P + w$, $A' = A$, and $B' = B \setminus \{w\}$ gives a partition satisfying (i) - (v), and having $|P'| > |P|$. This contradicts P being maximal in the original partition.
- Suppose that for all $w \in B$, uw is not an edge. Letting $P' = P - u$, $A' = A \cup \{u\}$, and $B' = B$ gives partition satisfying (i) - (iv), and having $|A'| > |A|$. This contradicts A being maximal in the original partition.

□

Lemma 3.4 implies Lemma 1.10, by taking G to be the red colour class of a 2-coloured complete graph. The following could be seen as a strengthening of Lemma 1.10, when one of the colour classes of K_n is connected.

Lemma 3.5. *Suppose that G is connected graph. Then at least one of the following holds.*

- (i) *There is a path P passing through all, but one vertex in G .*
- (ii) *There is a vertex-partition of G into a path P , and three nonempty sets A , B_1 , and B_2 such that $|A| = |B_1| + |B_2|$ and there are no edges between any two of A , B_1 , and B_2 .*

Proof. First suppose that for every path P , $G \setminus P$ is connected. Let P be a path in G of maximum length. Let v be an endpoint of P . By maximality, v cannot be connected to anything in $(G \setminus P) \cup \{v\}$. However, since $P - \{v\}$ is a path, $(G \setminus P) \cup \{v\}$ must be

connected, hence it consists of the single vertex v . Thus the path P passes through every vertex in G , proving case (i) of the lemma.

Now, we can assume that there exists a path P_0 such that $G \setminus P_0$ is disconnected. In addition, we assume that P_0 is a shortest such path. The assumption that G is connected implies that P_0 is not empty. Suppose that P_0 starts with v_1 and ends with v_2 . Let C_1, \dots, C_j be the connected components of $G \setminus P_0$, ordered such that $|C_1| \geq |C_2| \geq \dots \geq |C_j|$. The assumption of P_0 being a shortest path, such that $G \setminus P_0$ is disconnected, implies that v_1 and v_2 are both connected to C_t for each $t \in \{1, \dots, j\}$. Indeed if this were not the case, then either $P_0 - \{v_1\}$ or $P_0 - \{v_2\}$ would give a shorter path with the required property.

Let u_1 be a neighbour of v_1 in C_1 and u_2 a neighbour of v_2 in C_2 . Apply Lemma 3.4 to C_1 to obtain a partition of C_1 into a path P_1 and two sets X_1 and Y_1 , such that $|X_1| = |Y_1|$ and there are no edges between X_1 and Y_1 . Similarly, apply Lemma 3.4 to $C_2 \cup \dots \cup C_j$ to obtain a partition of $C_2 \cup \dots \cup C_j$ into a path P_2 and two sets X_2 and Y_2 , such that $|X_2| = |Y_2|$ and there are no edges between X_2 and Y_2 . In addition we can assume that P_1 is either empty or ends at u_1 and that P_2 is either empty or starts at u_2 . Since v_1u_1 and v_2u_2 are both edges, we can define a path $Q = P_1 + P_0 + P_2$. Let w_1 be the start of Q , and w_2 the end of Q . We have that either $w_1 \in C_1$ or $w_1 = v_1$ and either $w_2 \in C_2 \cup \dots \cup C_j$ or $w_2 = v_2$.

If each of the sets X_1, Y_1, X_2 , and Y_2 is nonempty, then case (ii) of the lemma holds, using the path Q , $A = X_1 \cup X_2$, $B_1 = Y_1$, and $B_2 = Y_2$.

Suppose that $X_1 = Y_1 = \emptyset$ and $X_2 = Y_2 \neq \emptyset$. In this case w_1 must lie in C_1 since we know that $P_1 \cup X_1 \cup X_2 = C_1 \neq \emptyset$. Therefore P_1 is nonempty, and so must contain w_1 .

Suppose that w_2 has no neighbours in $X_2 \cup Y_2$. Note that in this case $w_2 \neq v_2$ since otherwise $X_2 \cup Y_2 = C_2 \cup \dots \cup C_j$ would hold, and we know that v_2 has neighbours in $C_2 \dots C_j$. Therefore, we have $w_2 \in C_2 \cup \dots \cup C_j$, and so (ii) holds with $P = Q - \{w_1\} - \{w_2\}$ as our path, $A = X_2 \cup \{w_2\}$, $B_1 = Y_2$, and $B_2 = \{w_1\}$.

Suppose that w_2 has a neighbour x in $X_2 \cup Y_2$. Without loss of generality, assume that $x \in X_2$. If $|X_2| = |Y_2| = 1$, then case (i) of the lemma holds with $Q + x$ a path covering all the vertices in G except the single vertex in Y_2 . If $|X_2| = |Y_2| \geq 2$ then case (ii) holds with $P = Q + \{x\} - \{w_1\}$ as our path, $A = Y_2$, $B_1 = X_2 - \{x\}$, and $B_2 = \{w_1\}$.

The case when $X_1 = Y_1 \neq \emptyset$ and $X_2 = Y_2 = \emptyset$ is dealt with similarly. If $X_1 = Y_1 = X_2 = Y_2 = \emptyset$, then Q covers all the vertices in G , so case (i) holds. \square

The following lemma gives a characterization of split colourings of $K_{n,n}$.

Lemma 3.6. *Let $K_{n,n}$ be a 2-edge coloured balanced complete bipartite graph. The colouring on $K_{n,n}$ is split if and only if none of the following hold.*

- (i) $K_{n,n}$ is connected in some colour.
- (ii) There is a vertex u such that all the edges through u are the same colour.

Proof. Suppose that $K_{n,n}$ is not split and (i) fails to hold. We will show that (ii) holds. Let X and Y be the classes of the bipartition of $K_{n,n}$. Let C be any red component of $K_{n,n}$,

$X_1 = X \cap C$, $X_2 = X \setminus C$, $Y_1 = Y \cap C$, and $Y_2 = Y \setminus C$. If all these sets are nonempty, then G is split with classes X_1 , X_2 , Y_1 , and Y_2 . To see this note that there cannot be any red edges between X_1 and Y_2 , or between X_2 and Y_1 since C is a red component. There cannot be any blue edges between X_1 and Y_1 , or between X_2 and Y_2 since $K_{n,n}$ is disconnected in blue.

Assume that one of the sets X_1 , X_2 , Y_1 , or Y_2 is empty. If X_1 is empty, then C is entirely contained in Y and hence consists of a single vertex u , giving rise to case (ii) of the lemma. If X_2 is empty, then note that Y_2 is nonempty, since otherwise $C = K_{n,n}$ would hold contradicting our assumption that (i) fails to hold. Let u be any vertex in Y_2 . For any v , the edge uv must be blue, since $X \subseteq C$ holds. Thus again (ii) holds. The cases when Y_1 or Y_2 are empty are done in the same way by symmetry.

For the converse, note that if $K_{n,n}$ is split, then the red components are $X_1 \cup Y_1$ and $X_2 \cup Y_2$, and that the blue components are $X_1 \cup Y_2$ and $X_2 \cup Y_1$. It is clear that neither (i) nor (ii) can hold. \square

We now prove Theorem 1.8

Proof of Theorem 1.8. Suppose that the colouring of $K_{n,n}$ is split. Note that two monochromatic paths with different colours can intersect at most three of the sets X_1 , X_2 , Y_1 and Y_2 . This together with the assumption that X_1 , X_2 , Y_1 and Y_2 are all nonempty implies that $K_{n,n}$ cannot be partitioned into two monochromatic paths with different colours.

It remains to prove that every 2-coloured $K_{n,n}$ which is not split can be partitioned into two monochromatic paths.

The proof is by induction on n . The case $n = 1$ is trivial. For the remainder of the proof assume that the result holds for $K_{m,m}$ for all $m < n$.

Assume that the colouring on $K_{n,n}$ is not split. Lemma 3.6 gives us two cases to consider.

Suppose that $K_{n,n}$ satisfies case (i) of Lemma 3.6. Without loss of generality we can assume that $K_{n,n}$ is connected in red.

Apply Lemma 3.5 to the red colour class of $K_{n,n}$. If case (i) of Lemma 3.5 occurs, then the theorem follows since we may choose P to be our red path and the single vertex to be our blue path.

So we can assume that we are in case (ii) of Lemma 3.5. This gives us a partition of $K_{n,n}$ into a red path P , and three nonempty sets A , B_1 , and B_2 , such that $|A| = |B_1| + |B_2|$ and all the edges between A , B_1 , and B_2 are blue. Let $H = (A \cap X) \cup (B_1 \cap Y) \cup (B_2 \cap Y)$ and $K = (A \cap Y) \cup (B_1 \cap X) \cup (B_2 \cap X)$. Note that $K_{n,n}[H]$ and $K_{n,n}[K]$ are both blue complete bipartite subgraphs of $K_{n,n}$, since all the edges between A and $B_1 \cup B_2$ are blue. Notice that $|A| = |B_1| + |B_2|$ and $|X| = |Y|$ together imply that P contains an even number of vertices. This, together with the fact that the vertices of P must alternate between X and Y , implies that $|X \setminus P| = |Y \setminus P|$. However $X \setminus P = X \cap (A \cup B_1 \cup B_2)$ and $Y \setminus P = Y \cap (A \cup B_1 \cup B_2)$, so we have that

$$|X \cap A| + |X \cap B_1| + |X \cap B_2| = |Y \cap A| + |Y \cap B_1| + |Y \cap B_2|. \quad (1)$$

Equation (1), together with $|X \cap A| + |Y \cap A| = |Y \cap B_1| + |Y \cap B_2| + |X \cap B_1| + |X \cap B_2|$ implies that the following both hold:

$$|A \cap X| = |B_1 \cap Y| + |B_2 \cap Y|, \quad (2)$$

$$|A \cap Y| = |B_1 \cap X| + |B_2 \cap X|. \quad (3)$$

Thus $K_{n,n}[H]$ and $K_{n,n}[K]$ are balanced blue complete bipartite subgraphs of $K_{n,n}$ and so can each be covered by a blue path. If $H = \emptyset$ or $K = \emptyset$ holds, the theorem follows, since $V(K_{n,n}) = V(P) \cup H \cup K$.

So, we can assume that $H \neq \emptyset$ and $K \neq \emptyset$. Equation (2), together with $H \neq \emptyset$, implies that $(B_1 \cup B_2) \cap H \neq \emptyset$. Similarly (3) together with $K \neq \emptyset$, implies that $(B_1 \cup B_2) \cap K \neq \emptyset$. We also know that B_1 and B_2 are nonempty and contained in $H \cup K$. Combining all of these implies that at least one of the following holds.

(a) $B_1 \cap H \neq \emptyset$ and $B_2 \cap K \neq \emptyset$.

(b) $B_1 \cap K \neq \emptyset$ and $B_2 \cap H \neq \emptyset$.

Suppose that (a) holds. Choose $x \in B_1 \cap H$ and a blue path Q covering H and ending with x . Choose $y \in B_2 \cap K$ and a blue path R covering K and starting with y . Notice that $x \in X$ and $y \in Y$, so there is an edge xy . The edge xy must be blue since it lies between B_1 and B_2 . This means that $Q + R$ is a blue path covering $A \cup B_1 \cup B_2 = G \setminus P$, implying the theorem. The case when (b) holds can be treated identically, exchanging the roles of H and K .

Suppose that $K_{n,n}$ satisfies case (ii) of Lemma 3.6. Without loss of generality, this gives us a vertex $u \in X$ such that the edge uy is red for every $y \in Y$. Let v be any vertex in Y .

Suppose that the colouring of $K_{n,n} \setminus \{u, v\}$ is split with classes X_1, X_2, Y_1 , and Y_2 . In this case $B(X_1, Y_2)$, $B(X_2, Y_1)$, and $\{v\}$ are all connected in red, and u is connected to each of these by red edges. This means that $K_{n,n}$ is connected in red and we are back to the previous case.

So, suppose that the colouring of $K_{n,n} \setminus \{u, v\}$ is not split. We claim that there is a partition of $K_{n,n} \setminus \{u, v\}$ into two a red path P and a blue path Q such that either P is empty or P ends in Y . To see this, apply the inductive hypothesis to $K_{n,n} \setminus \{u, v\}$ to obtain a partition of this graph into a red path P' and a blue path Q' . If P' is empty or P' has an endpoint in Y , then we can let $P = P'$ and $Q = Q'$. Otherwise, the endpoints P' are in X , and so the endpoints of Q' in Y . Let x be the end of P' and y the end of Q' . If xy is red, let $P = P' + \{y\}$ and $Q = Q' - \{y\}$. If xy is blue, let $P = P' - \{x\}$ and $Q = Q' + \{x\}$. In either case, P and Q give a partition of $K_{n,n} \setminus \{u, v\}$ into two paths such that either P is empty or P has an endpoint in Y .

Suppose that P is empty. In this case we have a partition of $K_{n,n}$ into a red path $\{u, v\}$ and a blue path Q .

Suppose that P ends in a vertex, w , in Y . The edges uw and vw are both red, so $P + \{u\} + \{v\}$ is a red path giving the required partition of $K_{n,n}$ into a red path $P + \{u\} + \{v\}$ and a blue path Q . \square

As remarked in the introduction, there are split colourings of $K_{n,n}$ which cannot be partitioned into two monochromatic paths. The following lemma shows that three monochromatic paths always suffice.

Lemma 3.7. *Suppose that the edges of $K_{n,n}$ are coloured with two colours. Suppose that the colouring is split with classes $X_1, X_2, Y_1,$ and Y_2 . For any two vertices $y_1 \in Y_1$ and $y_2 \in Y_2$, there is a vertex-partition of $K_{n,n}$ into a red path starting at y_1 , a red path starting at y_2 , and a blue path.*

Proof. Without loss of generality, suppose that $X_1 \leq X_2$ and $Y_1 \leq Y_2$. This, together with $X_1 + X_2 = Y_1 + Y_2$ implies that $X_1 \leq Y_2$ and $Y_1 \leq X_2$ both hold.

$B(X_1, Y_2)$ is a red complete bipartite graph, so we can cover X_1 and $|X_1|$ vertices in Y_2 with a red path starting from y_1 . Similarly we can cover Y_2 and $|Y_2|$ vertices in X_1 with a red path starting from y_2 . The only uncovered vertices are in Y_2 and X_1 . All the edges between these are blue, so we can cover the remaining vertices with a blue path. \square

The following lemma gives an alternative characterization of 4-partite colourings of K_n .

Lemma 3.8. *Suppose that the edges of K_n are coloured with three colours. The colouring is 4-partite if and only if there is a red connected component C_1 and a blue connected component C_2 such that all of the sets $C_1 \cap C_2, (V(K_n) \setminus C_1) \cap C_2, C_1 \cap (V(K_n) \setminus C_2),$ and $(V(K_n) \setminus C_1) \cap (V(K_n) \setminus C_2)$ are nonempty.*

Proof. Suppose that we have a red component C_1 and a blue component C_2 as in the statement of the lemma. Let $A_1 = C_1 \cap (V(K_n) \setminus C_2), A_2 = (V(K_n) \setminus C_1) \cap C_2, A_3 = (V(K_n) \setminus C_1) \cap (V(K_n) \setminus C_2),$ and $A_4 = C_1 \cap C_2$. This ensures that the sets $A_1, A_2, A_3,$ and A_4 form the classes of a 4-partite colouring of K_n .

For the converse, suppose that $A_1, A_2, A_3,$ and A_4 form the classes of a 4-partite colouring. Choose $C_1 = A_1 \cup A_4$ and $C_2 = A_2 \cup A_4$ to obtain components as in the statement of the lemma. \square

We are now ready to prove Theorem 3.2.

Proof of Theorem 3.2. The two main cases that we will consider are when K_n is connected in some colour, and when K_n is disconnected in all three colours.

Suppose that K_n is connected in red. Apply Lemma 3.5 to the red colour class of K_n . If case (i) of Lemma 3.5 occurs, then the theorem follows since we can take P as our red path, the single vertex as our blue path and the empty set as our green path. so, suppose that case (ii) of Lemma 3.5 occurs, giving us a partition of K_n into a red path P and three sets $A, B_1,$ and B_2 such that $|A| = |B_1| + |B_2|$ and all the edges between $A, B_1,$ and B_2 are blue or green.

If the colouring on $B(A, B_1 \cup B_2)$ is not split, we can apply Theorem 1.8 to partition $B(A, B_1 \cup B_2)$ into a blue path and a green path proving the theorem.

So, assume $B(A, B_1 \cup B_2)$ is split with classes $X_1, X_2, Y_1,$ and Y_2 , such that $A = X_1 \cup X_2$ and $B_1 \cup B_2 = Y_1 \cup Y_2$. Then, the fact that $B_1, B_2, Y_1,$ and Y_2 are nonempty implies that one of the following holds.

- (i) $B_1 \cap Y_1 \neq \emptyset$ and $B_2 \cap Y_2 \neq \emptyset$.
- (ii) $B_1 \cap Y_2 \neq \emptyset$ and $B_2 \cap Y_1 \neq \emptyset$.

Assume that (i) holds. Choose $y_1 \in B_1 \cap Y_1$ and $y_2 \in B_2 \cap Y_2$. The edge y_1y_2 must be blue or green since it lies between B_1 and B_2 . Assume that y_1y_2 is blue. Apply Lemma 3.7 to partition $B(A, B_1 \cup B_2)$ into a blue path Q ending with y_1 , a blue path R starting from y_2 and a green path S . By joining Q and R , we obtain a partition of G into three monochromatic paths P , $Q + R$, and S , all of different colours. The cases when (ii) holds or when the edge y_1y_2 is green are dealt with similarly.

The same argument can be used if K_n is connected in blue or green. So, for the remainder of the proof, we assume that all the colour classes are disconnected. Let C be the largest connected component in any colour class. Without loss of generality we may suppose that C is a red connected component. Let D be a blue connected component. Let $C^c = V(K_n) \setminus C$ and $D^c = V(K_n) \setminus D$. One of the sets $C \cap D$, $C^c \cap D$, $C \cap D^c$, or $C^c \cap D^c$ must be empty. Indeed if all these sets were nonempty, then Lemma 3.8 would imply that the colouring is 4-partite, contradicting the assumption of the theorem.

We claim that $D \subseteq C$ or $D^c \subseteq C$ holds. To see this consider four cases depending on which of $C \cap D$, $C^c \cap D$, $C \cap D^c$ or $C^c \cap D^c$ is empty.

- $C \cap D = \emptyset$ implies that all the edges between C and D are green. This contradicts C being the largest component in any colour.
- $C^c \cap D = \emptyset$ implies that $D \subseteq C$.
- $C \cap D^c = \emptyset$ implies that $C \subseteq D$. Since C is the largest component of any colour, this means that $C = D$.
- $C^c \cap D^c = \emptyset$ implies that $D^c \subseteq C$.

If $D \subseteq C$ holds, then choose $v \in D$. If $D^c \subseteq C$ holds, then choose $v \in D^c$. In either case all the edges between v and C^c must be green.

Apply Lemma 3.4 to the red colour class of K_n in order to obtain a partition of K_n into a red path P and two sets A and B such that $|A| = |B|$ and all the edges between A and B are colours 2 or 3. In addition, P is either empty or starts at v . If either of the graphs $K_n[A]$ or $K_n[B]$ is disconnected in red, then we can proceed just as we did after we applied Lemma 3.5 in the previous part of the theorem. So assume that both $K_n[A]$ and $K_n[B]$ are connected in red. We claim that one of the sets A or B must be contained in C^c . Indeed otherwise C would intersect each of P , A , and B . Since P , $K_n[A]$, and $K_n[B]$ are connected in red, this would imply that $C = P \cup A \cup B = K_n$ contradicting K_n being disconnected in red. Without loss of generality we may assume that $B \subseteq C^c$. Therefore all the edges between v and B are green.

As before, if the colouring on $B(A, B)$ is not split, we can apply Theorem 1.8 to partition $B(A, B)$ into a blue path and a green path. Therefore assume that the colouring on $B(A, B)$ is split.

If the path P is empty, then we must have $v \in A$. Lemma 3.6 leads to a contradiction, since we know that all the edges between v and B are green, and $B(A, B)$ is split.

Therefore the path P is nonempty. We know that $B(A, B)$ is split with classes $X_1, X_2, Y_1,$ and Y_2 , such that $A = X_1 \cup X_2$ and $B = Y_1 \cup Y_2$. Choose $y_1 \in Y_1$ and $y_2 \in Y_2$ arbitrarily. Apply Lemma 3.7 to $B(A, B)$ to partition $B(A, B)$ into a green path Q ending with y_1 , a green path R starting from y_2 , and a blue path S . Notice that the edges y_1v and vy_2 are both green, so $P - \{v\}$, S , and $Q + \{v\} + R$ give a partition of K_n into three monochromatic paths, all of different colours.

□

3.2 Proof of Theorem 3.3

In this section, we prove Theorem 3.3. The proof has a lot in common with the proof of a similar theorem in [12].

Proof. Let $A_1, A_2, A_3,$ and A_4 be the classes of the 4-partition of K_n , with colours between the classes as in Definition 3.1. Our proof will be by induction on n . The initial case of the induction will be $n = 4$, since for smaller n there are no 4-partite colourings of K_n . For $n = 4$, the result is trivial. Suppose that the result holds for K_m for all $m < n$.

For $i = 1, 2, 3,$ and 4 we assign three integers $r_i, b_i,$ and g_i to A_i corresponding to the three colours as follows:

- (i) Suppose that A_i can be partitioned into three nonempty monochromatic paths $R_i, B_i,$ and G_i of colours red, blue, and green respectively. In this case, let $r_i = |R_i|,$ $b_i = |B_i|,$ and $g_i = |G_i|.$
- (ii) Suppose that A_i can be partitioned into three nonempty monochromatic paths $P_1, P_2,$ and Q such that P_1 and P_2 are coloured the same colour and Q is coloured a different colour. If P_1 and P_2 are red, then we let $r_i = |P_1| + |P_2| - 1.$ If Q is red, then we let $r_i = |Q|.$ If none of $P_1, P_2,$ or Q are red, then we let $r_i = 1.$ We do the same for “blue” and “green” to assign values to b_i and g_i respectively. As a result we have assigned the values $|P_1| + |P_2| - 1, |Q|,$ and 1 to some permutation of the three numbers $r_i, b_i,$ and $g_i.$
- (iii) Suppose that $|A_i| \leq 2.$ In this case, let $r_i = b_i = g_i = 1.$

For each $i \in \{1, 2, 3, 4\},$ A_i will always be in at least one of the above three cases. To see this, depending on whether the colouring on A_i is 4-partite or not, apply either Theorem 3.2 or the inductive hypothesis of Theorem 3.3 to $A_i,$ in order to partition A_i into three monochromatic paths $P_1, P_2,$ and P_3 at most two of which are the same colour. If $|A_i| \geq 3$ then we can assume that $P_1, P_2,$ and P_3 are nonempty. Indeed if $P_1, P_2,$ or P_3 are empty, then we can remove endpoints from the longest of the three paths and add them to the empty paths to obtain a partition into three nonempty paths, at most two of which are the same colour. Therefore, if $|A_i| \geq 3,$ then either Case (i) or (ii) above will hold, whereas if $|A_i| \leq 2,$ then Case (iii) will hold.

For each $i \in \{1, 2, 3, 4\}$, note that r_i , b_i , and g_i are positive and satisfy $r_i + b_i + g_i \geq |A_i|$. We will need the following definition.

Definition 3.9. A red linear forest F is A_i -**filling** if F is contained in A_i , and either F consists of one path of order r_i , or F consists of two paths F_1 and F_2 such that $|F_1| + |F_2| = r_i + 1$.

Blue or green A_i -filling linear forests are defined similarly, exchanging the role of r_i for b_i or g_i respectively. We will need the following two claims.

Claim 3.10. Suppose that $i \in \{1, 2, 3, 4\}$, and $|A_i| \geq 2$. There exist two disjoint A_i -filling linear forests with different colours for any choice of two different colours.

Proof. Claim 3.10 holds trivially from the definition of r_i , b_i , and g_i . □

Claim 3.11. Suppose that $i, j \in \{1, 2, 3, 4\}$ such that $i \neq j$ and $B(A_i, A_j)$ is red. Let m be an integer such that the following hold.

$$0 \leq m \leq r_i, \tag{4}$$

$$|A_i| - m \leq |A_j|. \tag{5}$$

There exists a red path P from A_i to A_j , of order $2|A_i| - m$, covering all of A_i and any set of $|A_i| - m$ vertices in A_j .

Proof. Note that we can always find an A_i -filling linear forest, F . If $|A_i| = 1$ this is trivial, and if $|A_i| \geq 2$, then this follows from Claim 3.10.

Suppose that F consists of one path of order r_i . By (4), we can shorten F to obtain a new path F' of order m . By (5), we can choose a red path, P , from A_i to A_j consisting of $A_i \setminus F'$ and any $|A_i| - m$ vertices in $A_j \setminus F'$. The path $P + F'$ satisfies the requirements of the claim.

Suppose that F consists of two paths F_1 and F_2 such that $|F_1| + |F_2| = r_i + 1$. By (4), we can shorten F_1 and F_2 to obtain two paths F'_1 and F'_2 such that $|F'_1| + |F'_2| = m + 1$. By (5), we can choose a red path, P , from A_i to A_j consisting of $A_i \setminus F'$ and any $|A_i| - m - 1$ vertices in A_j . By (5) there must be at least one vertex, v , in $A_j \setminus P$. The path $P + F'_1 + \{v\} + F'_2$ satisfies the requirements of the claim. □

We can formulate versions of Claim 3.11 for the colours blue or green as well, replacing r_i with b_i or g_i respectively.

To prove Theorem 3.3, we will consider different combinations of values of r_i , b_i , and g_i for $i = 1, 2, 3$, and 4 to construct a partition of K_n into three monochromatic paths in each case.

If a partition of K_n into monochromatic paths contains edges in the graph $B(A_i, A_j)$ for $i \neq j$, we say that $B(A_i, A_j)$ is a *target component* of the partition. Note that a partition of K_n into three monochromatic paths can have at most three target components. This is because a monochromatic path can pass through edges in at most one of graphs $B(A_i, A_j)$.

There are two kinds of partitions into monochromatic paths which we shall construct.

- We say that a partition of K_n is *star-like* if the target components are $B(A_i, A_j)$, $B(A_i, A_k)$, and $B(A_i, A_l)$, for (i, j, k, l) some permutation of $(1, 2, 3, 4)$. In this case, all the paths in the partition will have different colours.
- We say that a partition of K_n is *path-like* if the target components are $B(A_i, A_j)$, $B(A_j, A_k)$, and $B(A_k, A_l)$, for (i, j, k, l) some permutation of $(1, 2, 3, 4)$. In this case, two of the paths in the partition will have the same colour.

For $i \in \{1, 2, 3, 4\}$, it is possible to write down sufficient conditions on $|A_i|$, r_i , b_i , and g_i for K_n to have a partition into three monochromatic paths with given target components.

Claim 3.12. *Suppose that the following holds:*

$$|A_1| + |A_2| + |A_3| \leq |A_4| + r_1 + b_2 + g_3. \quad (6)$$

Then, K_n has a star-like partition with target components $B(A_4, A_1)$, $B(A_4, A_2)$, and $B(A_4, A_3)$ of colours red, blue, and green respectively.

Proof. Using (6), we can find three disjoint subsets S_1 , S_2 , and S_3 of A_4 such that $|S_1| = |A_1| - r_1$, $|S_2| = |A_2| - b_2$, and $|S_3| = |A_3| - g_3$ all hold. By Claim 3.11 there is a red path P_1 with vertex set $A_1 \cup S_1$, a blue path P_2 with vertex set $A_2 \cup S_2$, and a green path P_3 with vertex set $A_3 \cup S_3$. The paths P_1 , P_2 , and P_3 are pairwise disjoint and have endpoints in A_1 , A_2 , and A_3 respectively.

Depending on whether $A_4 \setminus (P_1 \cup P_2 \cup P_3)$ is 4-partite or not, apply either Theorem 3.2 or the inductive hypothesis to find a partition of $A_4 \setminus (P_1 \cup P_2 \cup P_3)$ set into three monochromatic paths Q_1 , Q_2 , and Q_3 at most two of which are the same colour.

We will join the paths P_1 , P_2 , P_3 , Q_1 , Q_2 , and Q_3 together to obtain three monochromatic paths partitioning all the vertices in K_n .

Suppose that all the Q_i are all of different colours, with Q_1 red, Q_2 blue, and Q_3 green. In this case $P_1 + Q_1$, $P_2 + Q_2$, and $P_3 + Q_3$ are three monochromatic paths forming a star-like partition of K_n .

Suppose that two of the Q_i are the same colour. Without loss of generality, we may assume that Q_1 and Q_2 are red and Q_3 is blue. In this case $Q_1 + P_1 + Q_2$, P_2 , and $P_3 + Q_3$ are three monochromatic paths forming a star-like partition of K_n . \square

Claim 3.13. *Suppose that the following all hold:*

$$|A_1| + |A_4| \leq |A_2| + |A_3| + b_4 + g_4 + g_1, \quad (7)$$

$$|A_3| + |A_2| \leq |A_1| + |A_4| + b_2 + g_2 + g_3, \quad (8)$$

$$|A_1| < |A_2| + g_1, \quad (9)$$

$$|A_3| < |A_4| + g_3. \quad (10)$$

Then K_n has a path-like partition with target components $B(A_1, A_2)$, $B(A_2, A_4)$, and $B(A_4, A_3)$ of colours green, blue, and green respectively.

Proof. Suppose that we have

$$|A_2| - |A_1| + g_1 \geq |A_4| - |A_3| + g_3. \quad (11)$$

The inequality (10), together with Claim 3.11 ensures that we can find a green path P_1 consisting of all of A_3 and $|A_3| - g_3$ vertices in A_4 .

There are two subcases depending on whether the following holds or not:

$$|A_2| - |A_1| \leq |A_4| - |A_3| + g_3. \quad (12)$$

Suppose that (12) holds. Let $m = |A_1| - |A_2| + |A_4| - |A_3| + g_3$. Note that $|A_1| - m \leq |A_2|$ holds by (10), that m is positive by (12), and that m is less than g_1 by (11). Therefore, we can apply Claim 3.11 to find a green path P_2 consisting of A_1 and $|A_1| - m$ vertices in A_2 . There remain exactly $|A_4| - |A_3| + g_3$ vertices in each of A_2 and A_4 outside of the paths P_1 and P_2 . Cover these with a blue path P_3 giving the required partition.

Suppose that (12) fails to hold. Note that (10) and the negation of (12) imply that $|A_2| > |A_1|$ which, together with the fact that $|A_1| > 0$, implies that $|A_2| \geq 2$. Therefore, we can apply Claim 3.10 to A_2 to obtain a blue A_2 -filling linear forest, B , and a disjoint green A_2 -filling linear forest, G . We construct a blue path P_B and a green path P_G as follows:

Note that $A_4 \setminus P_1$ is nonempty by (10), so let u be a vertex in $A_4 \setminus P_1$. If B is the union of two paths B_1 and B_2 such that $|B_1| + |B_2| = b_2 + 1$, then let $P_B = B_1 + \{u\} + B_2$. Otherwise B must be single path of order b_1 , and we let $P_B = B$.

Similarly, let v be a vertex in A_1 . If G consists of two paths G_1 and G_2 , we let $P_G = G_1 + \{v\} + G_2$. If G is a single path, we let $P_G = G$.

Note that the above construction and (8) imply that the following is true.

$$|A_2 \setminus (P_B \cup P_G)| \leq |A_1 \setminus (P_B \cup P_G)| + |(A_4 \setminus P_1) \setminus (P_B \cup P_G)|. \quad (13)$$

The negation of (12) is equivalent to the following

$$|A_2| \geq |A_1| + |(A_4 \setminus P_1)|. \quad (14)$$

Let P'_B and P'_G be subpaths of P_B and P_G respectively, such that the sum $|P'_B| + |P'_G|$ is as small as possible and we have

$$|A_2 \setminus (P'_B \cup P'_G)| \leq |A_1 \setminus (P'_B \cup P'_G)| + |(A_4 \setminus P_1) \setminus (P'_B \cup P'_G)|. \quad (15)$$

The paths P'_B and P'_G are well defined by (13). We claim that we actually have equality in (15). Indeed, since A_1 , A_2 , and $A_4 \setminus P_1$ are all disjoint, removing a single vertex from P'_B or P'_G can change the inequality (15) by at most one. Therefore, if the inequality (15) is strict, we know that P'_B and P'_G are not both empty by (14), so we can always remove a single vertex from P'_B or P'_G to obtain shorter paths satisfying (15), contradicting the minimality of $|P'_B| + |P'_G|$.

Equality in (15) implies that $|A_2 \setminus (P_1 \cup P'_B \cup P'_G)| = |(A_1 \cup A_4) \setminus (P_1 \cup P'_B \cup P'_G)|$, so we can choose a green path Q_G from A_1 to A_2 and a disjoint blue path Q_B from $(A_4 \setminus P_1)$ to A_2 such that $Q_B \cup Q_G = (A_1 \cup A_2 \cup A_4) \setminus (P_1 \cup P'_B \cup P'_G)$. The paths P_1 , $P'_B + Q_B$, and $P'_G + Q_G$ give us the required partition of K_n .

If the negation of (11) holds, we can use the same method, exchanging the roles of A_1 and A_3 , and of A_2 and A_4 . □

Obviously, there was nothing special about our choice of target components in Claims 3.12 and 3.13. We can write similar sufficient conditions for there to be a star-like partition or a path-like partition for any choice of target components. To prove Theorem 3.3, we shall show that either the inequality in Claim 3.12 holds or all four inequalities from Claim 3.13 hold for some choice of target components.

Without loss of generality we can assume that the following holds:

$$|A_1| \leq |A_2| \leq |A_3| \leq |A_4|. \quad (16)$$

Consider the following instances of Claims 3.12 and 3.13.

There is a star-like partition of K_n with target components $B(A_4, A_1)$, $B(A_4, A_2)$, and $B(A_4, A_3)$ of colours red, blue, and green respectively if the following holds:

$$|A_1| + |A_2| + |A_3| \leq |A_4| + r_1 + b_2 + g_3. \quad (A1)$$

There is a path-like partition of K_n with target components $B(A_1, A_2)$, $B(A_2, A_4)$, and $B(A_4, A_3)$ of colours green, blue, and green respectively if the following holds:

$$|A_1| + |A_4| \leq |A_2| + |A_3| + b_4 + g_4 + g_1, \quad (B1)$$

$$|A_3| + |A_2| \leq |A_1| + |A_4| + b_2 + g_2 + g_3, \quad (B2)$$

$$|A_1| < |A_2| + g_1,$$

$$|A_3| < |A_4| + g_3.$$

There is a path-like partition of K_n with target components $B(A_1, A_4)$, $B(A_4, A_3)$, and $B(A_3, A_2)$ of colours red, green, and red respectively if the following holds:

$$|A_1| + |A_3| \leq |A_2| + |A_4| + g_3 + r_3 + r_1,$$

$$|A_2| + |A_4| \leq |A_1| + |A_3| + g_4 + r_4 + r_2, \quad (C2)$$

$$|A_1| < |A_4| + r_1,$$

$$|A_2| < |A_3| + r_2.$$

There is a path-like partition of K_n with target components $B(A_1, A_3)$, $B(A_3, A_2)$, and $B(A_2, A_4)$ of colours blue, red, and blue respectively if the following holds:

$$\begin{aligned} |A_1| + |A_2| &\leq |A_3| + |A_4| + r_2 + b_2 + b_1, \\ |A_3| + |A_4| &\leq |A_1| + |A_2| + r_3 + b_3 + b_4, \end{aligned} \tag{D2}$$

$$\begin{aligned} |A_1| &< |A_3| + b_1, \\ |A_4| &< |A_2| + b_4. \end{aligned} \tag{D4}$$

There is a path-like partition of K_n with target components $B(A_1, A_4)$, $B(A_4, A_2)$, and $B(A_2, A_3)$ of colours red, blue, and red respectively if the following holds:

$$\begin{aligned} |A_1| + |A_2| &\leq |A_3| + |A_4| + b_2 + r_2 + r_1, \\ |A_3| + |A_4| &\leq |A_1| + |A_2| + b_4 + r_4 + r_3, \end{aligned} \tag{E2}$$

$$\begin{aligned} |A_1| &< |A_4| + r_1, \\ |A_3| &< |A_2| + r_3. \end{aligned} \tag{E4}$$

There is a path-like partition of K_n with target components $B(A_2, A_4)$, $B(A_4, A_1)$, and $B(A_1, A_3)$ of colours blue, red, and blue respectively if the following holds:

$$\begin{aligned} |A_1| + |A_2| &\leq |A_3| + |A_4| + r_1 + b_1 + b_2, \\ |A_3| + |A_4| &\leq |A_1| + |A_2| + r_4 + b_4 + b_3, \end{aligned} \tag{F2}$$

$$\begin{aligned} |A_2| &< |A_4| + b_2, \\ |A_3| &< |A_1| + b_3. \end{aligned} \tag{F4}$$

Note that all the unlabeled inequalities hold as a consequence of (16) and the positivity of r_i , b_i , and g_i . Thus, to prove the theorem it is sufficient to show that all the labeled inequalities corresponding to some particular letter A, B, C, D, E, or F hold. We split into two cases depending on whether (B1) holds or not.

Case 1: Suppose that (B1) holds.

Note that the following cannot all be true at the same time:

$$|A_3| + r_2 > |A_4| + g_3, \tag{17}$$

$$|A_2| + b_4 > |A_3| + r_2, \tag{18}$$

$$|A_4| + g_3 > |A_2| + b_4. \tag{19}$$

Indeed adding these three inequalities together gives $0 > 0$. Thus the negation of (17), (18), or (19) must hold.

The negation of (17) implies (B2) which, together with our assumption that (B1) holds, implies that all the inequalities corresponding to the letter ‘‘B’’ hold.

The negation of (18) implies (C2) which implies that all the inequalities corresponding to the letter ‘‘C’’ hold.

The negation of (19), together with $|A_3| \leq r_3 + b_3 + g_3$ implies that (D2) holds. The negation of (19), together with $g_3 > 0$ implies that (D4) holds. Therefore, all the inequalities corresponding to the letter “D” hold.

Case 2: Suppose that (B1) does not hold. If (C2) holds, then all the inequalities labeled “C” hold, so we assume that the negation of (C2) holds. We consider three subcases depending on which of (E4) and (F4) hold.

Subcase 1: Suppose that (E4) holds. If (E2) holds, then all the inequalities labeled “E” hold, so we assume that the negation of (E2) holds. Adding the negations of (B1), (C2), and (E2) together, and using $|A_4| \leq r_4 + b_4 + g_4$ gives the following:

$$|A_4| > |A_1| + |A_2| + |A_3| + g_1 + r_2 + r_3.$$

This is stronger than (A1) which implies that all the inequalities corresponding to the letter “A” hold.

Subcase 2: Suppose that (F4) holds. If (F2) holds, then all the inequalities labeled “F” hold, so we assume that the negation of (F2) holds. Adding the negations of (B1), (C2), and (F2) together, and using $|A_4| \leq r_4 + b_4 + g_4$ gives the following:

$$|A_4| > |A_1| + |A_2| + |A_3| + g_1 + r_2 + b_3.$$

This is stronger than (A1) which implies that all the inequalities corresponding to the letter “A” hold.

Subcase 3: Suppose that neither (E4) or (F4) hold. Adding the negations of (B1), (C2), (E4), and (F4) together, and using $|A_4| \leq r_4 + b_4 + g_4$ and $|A_3| \leq r_3 + b_3 + g_3$ gives the following:

$$|A_4| + g_3 > |A_1| + |A_2| + |A_3| + g_1 + r_2 + g_4.$$

This is stronger than (A1) which implies that all the inequalities corresponding to the letter “A” hold. \square

4 Discussion

Much of the research on partitioning coloured graphs has focused around Conjecture 1.2. Given the disproof of this conjecture, we will spend the remainder of this paper discussing possible directions for further work.

Although we only constructed counterexamples to Conjecture 1.2 for particular n in Section 2 of this paper, it is easy to generalize our construction to work for all $n \geq N_r$, where N_r is a number depending on r . To see this, one only needs to replace the assumption of “ m is an integer” with “ m is a real number” in Section 2, and replace expressions where m appears with suitably chosen integral parts. Doing this and choosing m appropriately

will produce r -colourings of K_n which cannot be partitioned into r monochromatic cycles for all sufficiently large n .

A weakening of Conjecture 1.2 is the following approximate version.

Conjecture 4.1. *For each r there is a constant c_r , such that in every r -edge coloured complete graph K_n , there are r vertex-disjoint monochromatic cycles covering $n - c_r$ vertices in K_n .*

This conjecture is open for $r \geq 3$. For $r = 3$, Theorem 1.3 shows that a version of Conjecture 4.1 is true with c_r replaced with a function $o_r(n)$ satisfying $\frac{o_r(n)}{n} \rightarrow 0$ as $n \rightarrow \infty$.

Another way to weaken Conjecture 1.2 is to remove the constraint that the cycles covering K_n are disjoint.

Conjecture 4.2. *Suppose that the edges of K_n are coloured with r colours. There are r (not necessarily disjoint) monochromatic cycles covering all the vertices in K_n .*

A weaker version of this conjecture where “cycles” is replaced with “paths” has appeared in [9]. Our method of finding counterexamples to Conjecture 1.2 relied on first finding graphs which cannot be partitioned into r monochromatic paths of different colours. For $r = 3$, using Theorem 3.2, it is easy to show that every 3-coloured complete graph can be covered by three (not necessarily disjoint) paths of different colours. Therefore for $r = 3$, it is unlikely that something similar to our constructions in Section 2 can produce counterexamples to Conjecture 4.2. It is even possible that, for all r , one can ask for the cycles in Conjecture 4.2 to have different colours.

As mentioned in the introduction, it is interesting to consider partitions of an edge coloured graph G other than the complete graph. Theorems 1.7 and 1.8 are results in this direction when G is a balanced complete bipartite graph. We make the following conjecture which would generalise Corollary 1.9.

Conjecture 4.3. *Suppose that the edges of $K_{n,n}$ are coloured with r colours. There is a vertex-partition of $K_{n,n}$ into $2r - 1$ monochromatic paths.*

This conjecture would be optimal, since for all r , there exist r -coloured balanced complete bipartite graphs which cannot be partitioned into $2r - 2$ monochromatic paths. We sketch one such construction here. Let X and Y be the classes of the bipartition of a balanced complete bipartite graph. We partition X into X_1, \dots, X_r and Y into Y_1, \dots, Y_r where $|X_i| = 10^i + i$ and $|Y_i| = 10^i + r - i$. The edges between X_i and Y_j are coloured with colour $i + j \pmod{r}$. It is possible to show that this graph cannot be partitioned into $2r - 2$ monochromatic paths. In [13], Haxell showed that every r -edge coloured balanced complete bipartite graph can be partitioned into $O((r \log r)^2)$ monochromatic cycles, which is the best known upper bound to how many paths are needed in Conjecture 4.3.

Acknowledgment

The author would like to thank his supervisors Jan van den Heuvel and Jozef Skokan for their advice and discussions.

References

- [1] P. Allen. Covering two-edge-coloured complete graphs with two disjoint monochromatic cycles. *Combin. Probab. Comput.*, 17(4):471–486, 2008.
- [2] J. Ayel. Sur l’existence de deux cycles supplémentaires unicolores, disjoints et de couleurs différentes dans un graphe complet bicolore. *Thèse de l’université de Grenoble*, 1979.
- [3] J. Balogh, J. Barát, D. Gerbner, A. Gyárfás, and G. Sárközy. Partitioning edge-2-colored graphs by monochromatic paths and cycles. *preprint*, 2012.
- [4] S. Bessy and S. Thomassé. Partitioning a graph into a cycle and an anticycle, a proof of Lehel’s conjecture. *J. Combin. Theory Ser. B*, 100(2):176–180, 2010.
- [5] R. Diestel. *Graph Theory*. Springer-Verlag, 2000.
- [6] P. Erdős, A. Gyárfás, and L. Pyber. Vertex coverings by monochromatic cycles and trees. *J. Combin. Theory Ser. B*, 51(1):90–95, 1991.
- [7] L. Gerencsér and A. Gyárfás. On Ramsey-type problems. *Ann. Univ. Sci. Budapest. Eötvös Sect. Math*, 10:167–170, 1967.
- [8] A. Gyárfás. Vertex coverings by monochromatic paths and cycles. *J. Graph Theory*, 7:131–135, 1983.
- [9] A. Gyárfás. Covering complete graphs by monochromatic paths. In *Irregularities of Partitions, Algorithms and Combinatorics*, volume 8, pages 89–91. Springer-Verlag, 1989.
- [10] A. Gyárfás and J. Lehel. A Ramsey-type problem in directed and bipartite graphs. *Pereodica Math. Hung.*, 3:299–304, 1973.
- [11] A. Gyárfás, M. Ruszinkó, G. Sárközy, and E. Szemerédi. An improved bound for the monochromatic cycle partition number. *J. Combin. Theory Ser. B*, 96(6):855–873, 2006.
- [12] A. Gyárfás, M. Ruszinkó, G. Sárközy, and E. Szemerédi. Partitioning 3-colored complete graphs into three monochromatic cycles. *Electron. J. Combin.*, 18(1), 2011.
- [13] P. Haxell. Partitioning complete bipartite graphs by monochromatic cycle. *J. Combin. Theory Ser. B*, 69:210–218, 1997.
- [14] T. Łuczak, V. Rödl, and E. Szemerédi. Partitioning two-colored complete graphs into two monochromatic cycles. *Combin. Probab. Comput.*, 7:423–436, 1998.
- [15] G. Sárközy. Monochromatic cycle partitions of edge-colored graphs. *J. Graph Theory*, 66:57–64, 2011.