



BIROn - Birkbeck Institutional Research Online

Kelly, Jim and Barnes, Paul and Fisher, G.R. (2001) Long period polytype boundaries in silicon carbide. *Ferroelectrics* 250 , pp. 187-190. ISSN 0015-0193.

Downloaded from: <https://eprints.bbk.ac.uk/id/eprint/400/>

Usage Guidelines:

Please refer to usage guidelines at <https://eprints.bbk.ac.uk/policies.html>
contact lib-eprints@bbk.ac.uk.

or alternatively

**Birkbeck ePrints: an open access repository of the
research output of Birkbeck College**

<http://eprints.bbk.ac.uk>

Kelly, J.F.; Barnes, P.; Fisher, G.R. (2001) Long period polytype boundaries in silicon carbide. *Ferroelectrics* **250**: 187-190.

This is an author-produced version of a paper published in *Ferroelectrics* (ISSN 0015-0193). This version has been peer-reviewed, but does not include the final publisher proof corrections, published layout, or pagination.

All articles available through Birkbeck ePrints are protected by intellectual property law, including copyright law. Any use made of the contents should comply with the relevant law.

Citation for this version:

Kelly, J.F.; Barnes, P.; Fisher, G.R. (2001) Long period polytype boundaries in silicon carbide. *London: Birkbeck ePrints*. Available at:
<http://eprints.bbk.ac.uk/archive/00000400>

Citation for the publisher's version:

Kelly, J.F.; Barnes, P.; Fisher, G.R. (2001) Long period polytype boundaries in silicon carbide. *Ferroelectrics* **250**: 187-190.

<http://eprints.bbk.ac.uk>

Contact Birkbeck ePrints at lib-eprints@bbk.ac.uk

Long Period Polytype Boundaries in Silicon Carbide

J.F. KELLY¹, P. BARNES¹ and G.R. FISHER²

1 Industrial Materials Group, School of Crystallography, Birkbeck College,
University of London, Malet Street, WC1E 7HX, UK.

2 Electronic Materials Inc. Mailzone 6, 501 Pearl Drive, P.O. Box 8, St. Peter's,
MO63376, U.S.A.

Abstract

A significant gap in our understanding of polytypism exists, caused partly by the lack of experimental data on the spatial distribution of polytype coalescence and knowledge of the regions between adjoining polytypes. Few observations, Takei & Francombe (1967)¹ apart, of the relative location of different polytypes have been reported. A phenomenological description of the boundaries, exact position of one-dimensional disorder (1DD) and long period polytypes (LPP's) has been made possible by synchrotron X-ray diffraction topography (XRDT).

1. On the origins of silicon carbide

Silicon carbide may be older than our solar system, having wandered through the Milky Way for billions of years as stardust generated in the atmospheres of carbon rich red giant stars. The gravitational coalescence of our solar system trapped these micron-sized SiC grains in meteorites. Recent analysis of carbonaceous chondrites has revealed that these starry messengers contain anomalous isotopic ratios of carbon and silicon, indicating an origin from outside the solar system². The idea that a silicon-carbon bond might exist in nature had been proposed as early as 1824³; *carborundum* dates from 1892.

2. Unique behaviour – polytypism, semiconductor and gemstone

The word *polytypie* entered the literature in 1912 when Baumhauer⁴ attempted to describe materials that crystallise into modifications that differ unidirectionally. However polytypism did not attract widespread attention until studies in the 1940/50's revealed new polytypes. An improvement in the sublimation growth of SiC by Lely⁵ enabled its wide bandgap ($E_g \sim 3\text{eV}$) semiconductor potential to be further explored. Manufacturing advances by GEC Hirst Research Centre U.K. in the 1960's led directly to the availability of the crystals used in the present survey. Despite this potential the poor material quality, has handicapped device development. One stumbling block appears to be lack of a complete theoretical description⁶ of the prolific tendency for SiC to form so many polytypic modifications, including long period polytypes (LPP's).

3. The synchrotron topography story so far

By 1990 the potential of a synchrotron radiation source for imaging polytypic materials had been well demonstrated by Fisher & Barnes⁷, showing that it was possible to locate polytype positions along the c-axis using the method of edge topography. Further with the improved resolution that became available at second-generation machines Barnes et al. (1991)⁸ were able to observe fine one-dimensionally disordered (1DD) layers at polytype boundaries. This enabled the construction of complete spatial models of complex patterns of

polytypism occurring in practice. A unique database has now been compiled from the results of a survey, to date, of 132 such edge profiles distinguishing the common 6H, 4H, 15R polytypes and LPP's from regions of 1DD. With the broad classification scheme developed by Kelly et al.⁹ the authors have been able to describe polytype coalescence in terms of a non-degenerate sandwich model. Complex features such as LPP's and thin 1DD layers appear to be found as essential ingredients of polytype coalescence in these models (e.g. Fig1). Altogether 23 of the 135 crystals in this survey contain a measurable LPP repeat as distinct from a 1DD layer; these are listed in Table 1.

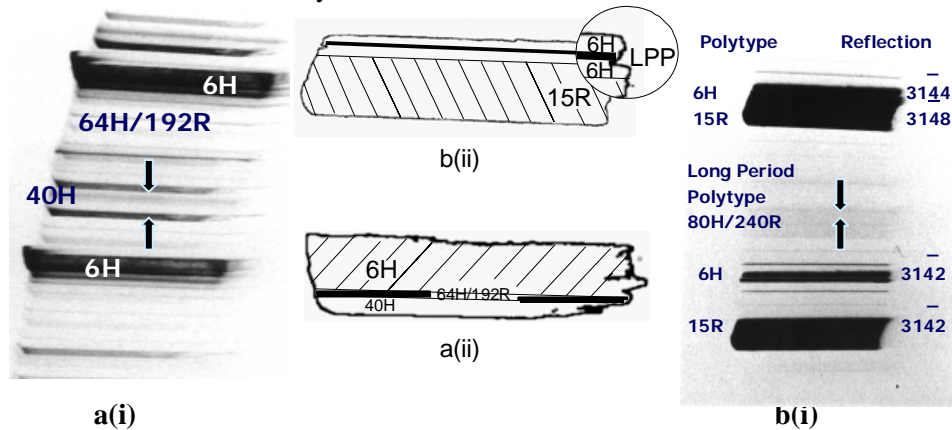

Figure 1: The current status of polytype model building from SiC synchrotron topographs illustrated with two examples a and b. a(i) A rare example of two LPP's in the same crystal (J113) assigned as 40H/120R (arrowed reflections) and 64H/192R. a(ii) A model of J113 termed an American Club Sandwich (ACS)⁹: 6H+1DD(5µm)+6H+64H/192R+1DD(40µm)+40H. b(i) Over-exposed indexed region from J108 showing the LPP reflections. b(ii) A model of J108 (with magnifying lens x50): 15R+6H+LPP+6H+1DD(30µm)+6H ACS.

4. Long period polytype boundaries and nearest neighbours

While searching for a scheme to classify polytype nearest neighbour relationships in SiC it became apparent that it was possible to identify LPP repeats and measure their widths (µm) on the topographs. Table 1 constitutes the only known database on experimentally determined SiC long period polytype neighbours. From the survey of 135 crystals, which has yielded 25 LPP's, only two cases could be found where more than one LPP is present (Figure 1 a). It is interesting to note that the shorter of the LPP's in both cases is on the outside face of the crystal, in keeping with the general sandwich rule⁹ (LPP's are always sandwiched between the shorter polytypes). In all other cases only a single LPP is found to coalesce with the common 6H,15R,4H polytypes. No obvious pattern of preference for polytype coalescence emerges and no correlation between LPP width and crystallographic repeat could be found.

Table 1: All long period polytypes found in a survey of SiC edges. The LPP's are shown relative to their immediate adjacent neighbours/next nearest ordered

polytype; – indicates the crystal edge. The sandwich model acronyms⁹ are: OS =open, DFS=doubly filled, ACS= American club, SS=simple, AS =asymmetric.

Crystal number	Polytype neighbour	Long period polytype repeat	Polytype neighbour (other side)	LPP (μm)	Model
J1	6H 1DD (270μm)	78H/234R *24H/72R	1DD (270μm)/LPP* -	20 200	ACS
J26	6H	152H/456R ⁽⁸⁾	6H	12.5	ACS
J31	4H	24H/72R	1DD (1225μm)/6H	260	DFS
J33	15R	78H/234R ⁽⁹⁾	1DD (70μm)/6H	50	DFS
J34	6H	201H/603R	6H	20	AS
J40	4H	106H/318R	1DD (145μm)/15R	15	DFS
J43	6H	24H/72R	6H	300	SS
J48	6H	342H/1026R	-	20	ACS
J59	6H	146H/438R ⁽⁹⁾	1DD (300μm)	10	OS
J64	6H	42H/126R ⁽⁸⁾	1DD (15μm)/6H	15	DFS
J101	6H	24H/72R	6H	70	ACS
J105	4H	201H/603R	1DD (270μm)/15R	20	ACS
J108/G31	6H	80H/240R	6H	20	ACS
J110/G158	6H	130H/390R	1DD (30μm)/8H	5	ACS
J113/G104	6H 1DD (40μm)	64H/192R *40H/120R	1DD (40μm)/LPP* -	20 150	ACS
J115/G185	6H	474H/1422R	1DD (270μm)	7.5	OS
J123/G111	6H	66H/198R	15R	50	ACS
J126/G39	6H	24H/72R	1DD (20μm)	90	OS
J128/G122	6H/1DD (110μm)	106H/318R	-	25	OS
J129/G159	6H	27H/81R	1DD (280μm)	70	OS
J131/G117	6H	72H/216R	8H	20	ACS
J133/G88	15R	289H/867R	1DD (320μm)/15R	30	ACS
J135/G163	6H	106H/318R	1DD (1380μm)	20	OS

The general trend of polytypism in SiC that is observed from Table 2 is in broad agreement with the theoretical predictions, of short period stability, as predicted by the ANNNI model which is discussed further in the next section.

Table 2: Statistical frequency of the common polytypes in the survey.

6H	15R+6H	4H+6H	15R+4H+6H	8H+6H	21R+6H	21R+15R+6H	Total
54	38	23	14	1	1	1	132

5. The Axial Next Nearest Neighbour Ising model and polytype boundaries

Elliott (1961)¹⁰ introduced the axial next nearest neighbour Ising model (ANNNI) which applied to anisotropic couplings with competing interactions leads to infinitely many commensurate phases and “the devil’s staircase”. Price and Yeomans (1984)¹¹ using the same approach showed that the ANNNI model provides a simple equilibrium mechanism whereby short range couplings lead to the existence of polytypes with very long stacking sequences. After a lengthy computational study into the origin of SiC polytypes Heine et al. (1992)¹² have speculated on the nature of the higher order polytypes, noting that this is beyond the limit of calculation. In summary confirmation of the relative absence of odd numbers of bands in the Zhdanov symbol of polytypes and the frequency of regular polytypes with long periods compared with random stacking sequences

(which mathematically are infinitely more probable) is the kind of experimental detail that the theoreticians hope can distinguish between mechanisms.

6. LPP boundaries and one-dimensional disorder

Theoreticians bemoan the lack of experimental data on SiC polytype coalescence. This paper gives the most extensive and detailed database to date from which we can test theoretical predictions and pose fundamental evidence that the theoreticians need to address. In this spirit we summarise the main conclusions on the spatial extent of long period polytypism in SiC:

- One-dimensional disorder (1DD) is far more common than previously realised, exemplified by the very thin ($\sim 5\mu\text{m}$) layers reported earlier. In total 106/135 crystals display a 1DD layer (in some cases more than one).
- This observation confirms the theoreticians' implication that the existence of random stacking sequences of layers is more likely than regular LPP's. Here the experimental evidence is overwhelming: 106 crystals contain 1DD layers as compared to 23 crystals containing LPP's.
- The lack of reporting on LPP coalescence is now directly addressed; we can say that the LPP's are usually associated with 1DD's and that they do not normally coalesce on both sides directly to the common 15R, 4H polytypes.
- Furthermore the sandwich rule^{7,9} applies even when two arbitrarily long LPP's are found to coalesce together, the shorter LPP outermost (J1, J113).
- Again the predominance of the 6H polytype is emphasised by its frequency and obvious syntactic coalescence to the long period polytypes.

Notwithstanding the above points Jagodzinski (1995)¹³ has indeed pointed to the need to assess the role of disorder in the equilibrium conditions of polytype formation. We look forward to comments from other experimentalists and invite theoreticians to critically evaluate our findings in attempting to reach a consensus on a unified view of polytypism in silicon carbide.

Acknowledgments The authors gratefully acknowledge the facilities of the Daresbury Laboratory, personnel (station 7.6) and the EPSRC for beam time.

References

1. Takei W.J., Francombe M.H., *J. Appl. Phys.*, **18**, 1589-1592 (1967).
2. Clayton D.D., *Astrophysical Journal*, **484**, L67-L70 (1997).
3. Berzelius J.J., *Ann. Phys. Chemie.*, **1**, 169-230 (1824).
4. Baumhauer H., *Zeit. Krist.*, **50**, 33-39 (1912).
5. Lely J.A., *Ber. Deutsch. Keram. Ges.*, **32**, 229-231 (1955).
6. Trigunayat G. C., *Solid State Ionics*, **48**, 3-70 (1991).
7. Fisher G.R., Barnes P., *Phil. Mag.*, **B61**, 217-236 (1990).
8. Barnes P., Kelly J.F., Fisher G.R., *Phil. Mag. Lett.*, **64**, 7-13 (1991).
9. Kelly J.F., Barnes P., Fisher G.R., *Radiat. Phys. Chem.*, **45**, 509-522 (1995).
10. Elliot R.J., *Phys. Rev.*, **124**, 346-353 (1961).
11. Price G.D., Yeomans J., *Acta. Cryst.* **B40**, 448-454 (1984).
12. Heine V., Cheng C., Needs R.J., *Mat. Sci. Eng.*, **B11**, 55-60 (1992).
13. Jagodzinski H., *Zeit. Krist.*, **210**, 481-488 (1995).